

**TOWN OF ULYSSES
NEW YORK**

**STANDARD SPECIFICATIONS
AND DETAILS
FOR WATER FACILITIES**

APPROVED BY ULYSSES TOWN BOARD

September 15, 2003

Amended December 9, 2003

TOWN of ULYSSES
BOARD of WATER
COMMISSIONERS

10 Elm Street
Trumansburg, New York 14886

TOWN OF ULYSSES

10 ELM STREET
TRUMANSBURG, NEW YORK 14886

STANDARD SPECIFICATIONS
AND DETAILS
FOR WATER FACILITIES

APPROVED BY ULYSSES TOWN BOARD

September 15, 2003

DATE

PREPARED BY:

BARTON & LOGUIDICE, P.C.
CONSULTING ENGINEERS
290 ELWOOD DAVIS ROAD
BOX 3107
SYRACUSE, NEW YORK 13220

TABLE OF CONTENTS

<u>SECTION</u>	<u>PAGE</u>
1.0 GENERAL	1
1.1 Local Law	1
1.2 Design Standards	1
1.3 Submittals	1
1.4 Coordination of Work with Superintendent	2
1.5 Materials and Workmanship	3
1.6 Tests and Inspections	3
1.7 Manufacturers	4
1.8 Extensions of Water Mains	4
2.0 MATERIALS	5
2.1 Pipe	5
2.2 Pipe Fittings	6
2.3 Gate Valves	7
2.4 Valve Boxes	8
2.5 Copper Tubing	8
2.6 Corporation Stops	9
2.7 Curb Stops	10
2.8 Curb Boxes	10
2.9 Brass Fittings	10
2.10 Flexible Pipe Couplings	11
2.11 Tapping Sleeve and Valve	11
2.12 Restraining Rods and Clamps	12
2.13 Hydrants	12
2.14 Meters	13
2.15 Tile Set Meter Box	13
2.16 Backflow Prevention Valve	13
2.17 Pressure Reducing Valve	14
2.18 Thrust Blocks	14
2.19 Lining, Special Backfill and Special Backfill Mix	14
3.0 INSTALLATION	16
3.1 General	16
3.2 Installation of Ductile Iron Water Mains and Appurtenances	22

3.3	Tapping Sleeve and Valve Installation	24
3.4	Valve Box Installation	24

TABLE OF CONTENTS

<u>SECTION</u>		<u>PAGE</u>
3.5	Curb Box Installation	24
3.6	Service Line Installation	24
3.7	Flexible Coupling Installation	25
3.8	Hydrant Installation	25
3.9	Meter Installation	26
3.10	Backflow Prevention Valve Installation	26
3.11	Pressure Reducing Valve Installation	27

STANDARD DETAILS

Figure 1 - Pipe Laying Detail

Figure 2 - Typical Cross (Culvert, Sanitary Sewer or Drainage Course)

Figure 3 - Valve Box for 12-Inch Valves and Smaller

Figure 4 - Hydrant Assembly

Figure 5 - 3/4" or 1" Service Connection

Figure 6 - Water Meter Installation

Figure 7 - Tile Set Meter Detail for Buildings Greater Than 150-Foot Setback

1.0 GENERAL

1.1 Local Law

Construction of all new water mains, water main extensions, service laterals, pump stations, meter pits, and appurtenant facilities shall conform to Town of Ulysses Local Law No. 1 dated 2003 hereinafter referred to as Local Law.

1.2 Design Standards

Design of all water mains, water main extensions, service laterals, pump stations, and appurtenant facilities shall comply with these specifications, Recommended Standards as adopted by the Great Lakes - Upper Mississippi River Board of State, Public Health and Environmental Managers (i.e. Ten States Standards), and in strict conformance with all requirements of New York State Department of Health (NYSDOH) and/or Tompkins County Health Department, whichever is more stringent.

1.3 Submittals

The following shall be submitted to the Superintendent and the Town Engineer for review, and shall require approval prior to incorporation into the work or acceptance of facilities as applicable:

- a. Design plans and specifications for water mains, water main extensions, pump stations and other appurtenant facilities proposed for construction by any person in accordance with Local Law;

- b. Manufacturer's catalog cuts, specifications, performance data, shop drawings and other such data as the Superintendent or Town Engineer shall request to clearly identify characteristics of materials and equipment proposed to be incorporated into the work;
- c. Contractor's proposed work schedule showing anticipated commencement and completion of all salient portions of the work;
- d. All test results, test reports and certifications as required by this Specification and Local Law;
- e. Record drawings as required by Local Law; and
- f. Bonds and insurance certificates as required by Local Law.

1.4 Coordination of Work with Superintendent

All work and work schedules shall be coordinated with the Superintendent. The Superintendent will make himself or herself available for inspections and other matters requiring Superintendent's inspection, approval and/or attention as required by Local Law and this Specification. However, the Superintendent shall not be obligated to conform to schedules proposed by the Customer¹.

¹As used in this document, Customer means the Applicant, Customer, Developer, Contractor and/or others working on behalf of the Applicant or Customer in actions related to extending water mains or services.

1.5 Materials and Workmanship

All workmanship, materials, equipment and appliances shall comply in all respects with the applicable Specifications, unless specific exception is made in writing at the time of approval by the Superintendent or Town Engineer.

All materials furnished or incorporated in the work shall be new, unused and of the quality and characteristics specified. If the quality or characteristics of any material are not specifically set forth in the Contract Documents, the material used shall be that customarily used in first class work of a similar nature and character.

All workmanship in manufacture and construction not specifically covered in the Specifications shall be equal to that customarily used in first class work of a similar nature and character. The Contractor shall exercise special care during construction to make all structures watertight.

1.6 Tests and Inspections

All materials, equipment and workmanship shall be subject to inspection, examination and tests by the Superintendent, or persons designated by him or her, at any and all times during manufacture or construction and at any place or places where manufacture or construction are performed.

All laboratory tests called for in the Specifications or requested by the Superintendent shall be performed at the Customer's expense, and the Customer shall furnish and deliver to the laboratory all requisite samples. Documentary evidence that materials pass the required inspection and tests shall be furnished to the Superintendent by the Customer prior to the use of the materials in the work.

No work shall be covered until inspected and approved by the Superintendent or his or her representative. If any work shall be covered over without the consent or approval of the Superintendent, the Customer shall uncover the work upon request of the Superintendent. Uncovering, recovering and restoring the work shall be at the Customer's expense whether or not the work is found to be defective.

1.7 Manufacturers

All items of equipment of like type shall be the product of one manufacturer, unless specified otherwise or specifically permitted by the Superintendent or Town Engineer.

Unless otherwise specified, shown or permitted, all equipment and materials shall be the product of manufacturers who have built equipment or produced materials of a like or similar type, character, size and capacity for at least three years prior to submittal for approval and who, if requested by the Superintendent, shall submit evidence thereof. Where only one (1) product/manufacturer is named herein, that specific product shall be supplied and installed. Should conditions exist where the named product is no longer available, the Superintendent shall have sole discretion to determine an acceptable replacement.

1.8 Extensions of Water Mains

1.8.1 All new water main extensions shall be of the same diameter as the main to which it is to be connected, unless otherwise approved by the Superintendent. [The new extension shall extend to the furthest boundary line of the last property to be provided water service by the proposed

extension.]

1.8.2 All new water main extensions shall include services to properties on both sides of the road should said parcels opposite the water main be within the Town of Ulysses, and shall include corporation stop, copper tubing and curb stops in accordance with these specifications.

2.0 MATERIALS

2.1 Pipe

2.1.1 All water main pipes to be furnished and installed shall be Class 50 ductile iron, double cement-lined pipe, unless otherwise approved by the Superintendent, and shall conform to the following specifications:

Push-On Joint Pipe:	AWWA C111/ANSI A21.11 AWWA C151/ANSI A21.51
Mechanical Joint Pipe:	AWWA C111/ANSI A21.11 AWWA C151/ANSI A21.51
Flanged Joint Pipe:	AWWA C115/ANSI A21.15 AWWA C151/ANSI A21.51
Cement-Mortar Lining:	AWWA C104/ANSI A21.4
Polyethylene Encasement:	AWWA C105

2.1.2 The pipe shall be supplied with two metallic wedges, sufficient to assure electrical conductivity, for each joint. Joints for all straight buried pipes shall be of the push-on self-centering, rubber-gasket type, except where thrust restraint is required. Exposed pipe and fittings shall have flanged joints. Transition gaskets shall be provided as required at mechanical joint fittings and pipe ends when a pipe of material other than ductile iron is inserted into the mechanical joint. Where oil and fuel hydrocarbons may be encountered in the trench or where as shown on

design plans, all mechanical joint gasket materials shall be nitrile rubber with sufficient acrylonitrile content to resist deterioration from oil and fuel.

2.1.3 Thrust restraint shall be provided using restrained mechanical joints or Field Lok gaskets as manufactured by US Pipe for all joints within the required restraining area.

2.1.4 Concrete Thrust Blocks and Anchors shall be sized for the internal pressure.

2.1.5 The exterior of all ductile iron pipes shall be covered with an asphalt coating having a thickness of approximately 1 mil.

2.1.6 All ductile iron pipe, fittings, valves and appurtenances shall be encased in linear low density polyethylene. The polyethylene film shall be 8 mil, Class C tubes or sheets.

2.2 Pipe Fittings

2.2.1 All fittings shall be double cement-lined cast iron with a 250-psi rating. Joints on buried fittings and specials shall be of mechanical joint type. Bolts and nuts for buried fittings shall be "Cor-Ten". Exposed fittings shall have flanged joints. All fittings shall conform to the following specifications:

Push-On Joint Fittings:	AWWA C110/ANSI A21.10
Mechanical Joint Fittings:	AWWA C110/ANSI A21.10
Flanged Fittings:	AWWA C110/ANSI A21.10
Cement-Mortar Lining:	AWWA C104/ANSI A21.4

2.3 Gate Valves

2.3.1 All line valves 12 inches and less shall be gate valves as manufactured by Kenseal II RW as manufactured by Kennedy or Clow Valve Co. All gate valves shall be of the non-rising stem, resilient seated type. Resilient seated gate valves for underground use shall be furnished in accordance with the requirements of the latest revision of AWWA C509, but shall meet the specific requirements and exceptions to the aforementioned specifications, which follow:

- a. Resilient seated gate valves shall have mechanical joint end with accessories.
- b. Resilient seated gate valves shall open by turning counterclockwise. The body shall be ductile or cast iron. The shaft shall be made of bronze with “O” ring seals and shall be lubricated and ready for use.
- c. Operating nuts shall be 2 inches square and shall be loosely fitted on the stems.
- d. All resilient seated gate valves shall be noted for 200-psi working pressure and 400-psi test pressure.
- e. All iron work, after being thoroughly cleaned, shall be coated with asphaltum varnish.

2.4 Valve Boxes

2.4.1 Valve boxes shall be provided at all underground gate valves to be installed. Valve boxes shall be 5-1/4-inch shaft size and the three (3)-piece screw type, and shall be thoroughly coated with two coats of asphaltum varnish. Valve box shall be Mueller Style H-10360, or Bigham & Taylor.

2.4.2 The word "WATER" and an arrow pointing in a counterclockwise direction with the word "OPEN" shall be cast in the valve box cover.

2.4.3 The minimum depth of cover over the valve shall be 5 feet. Valve box extensions shall be required where depth of the valve exceeds 5 feet.

2.5 Copper Tubing

2.5.1 All water service pipe shall be seamless Type K, soft drawn copper, conform to AWWA C800 and ASTM B88 and be in the nominal sizes of 3/4", 1", 1-1/2" and 2" unless specified otherwise by the Town Engineer.

2.5.2 A continuous length of copper tubing shall be used between the corporation and curb stop, between curb stops, or between the curb stop and the blowoff, unless specifically permitted by the Town Engineer. No more than one buried union shall be installed between the curb stop and the pressure-reducing valve.

2.5.3 Couplings for joining copper shall be Mueller "H-15405".

2.6 Corporation Stops

2.6.1 Corporation stops shall be Mueller “B-25008” ball corporation valves or McDonald and shall be equipped with the standard AWWA C800-66 inlet thread.

2.6.2 The maximum size corporation stop permitted in the barrel of gray-Iron or ductile iron pipe, without the use of service clamps, shall be as follows:

Pipe Size (inches)	4	6	8	10	12	16
Tap Size (inches)	$\frac{3}{4}$	$\frac{3}{4}$	1	1- $\frac{1}{2}$	1- $\frac{1}{2}$	2

2.6.3 For connections larger than those appearing in the above table or connections into PVC or AC pipe, a service clamp shall be used. Service clamps for ductile iron, PVC and AC water main shall be Mueller “DR1S Series Single Strap Ductile Iron Service Saddles” for services 1-inch and smaller and Mueller “DR2S Series Double Strap Ductile Iron Service Saddle” for service 1-1/4 inch and larger. All service clamps shall feature ASTM A395 ductile iron body, 304L stainless steel straps and hardware, and Nitrile O-ring gasket.

2.6.4 Service clamps for High Density Polyethylene (HDPE) water main shall be specifically designed for use with HDPE pipe, and shall include spring washers or other device to account for thermal expansion. Service clamps for HDPE shall be Smith Blair “315 Single Strap Ductile Iron Service Saddles” for services 1-inch and smaller and Smith Blair “Double Strap Ductile Iron Service Saddles” for service 1-1/4 inch and larger. All service clamps shall feature ASTM A536 ductile iron body, 304 stainless steel straps and hardware, and Nitrile O-ring gasket.

2.6.5 The maximum size tap in ductile iron, PVC, AC, or HDPE pipe shall be 2 inches. Connections larger than 2 inches shall be made with tapping sleeves and valves.

2.7 Curb Stops

2.7.1 Curb stops shall be the Mark II Oriseal type as manufactured by the Mueller Company, "H-15209", or McDonald.

2.8 Curb Boxes

2.8.1 Curb boxes used with curb stops of 1-1/4-inch size and smaller shall be extension type with one-piece lid Mueller "H-10314", or McDonald.

2.8.2 Curb boxes used with curb stops of 1-1/2 inches and 2 inches shall be Arch pattern (improved extension type), Mueller "H-10386".

2.8.3 All curb boxes shall be telescopic and shall have a collapsed length of 4-1/2 feet and a fully extended length of at least 5-1/2 feet. Covers shall be furnished with the word "WATER" cast in and shall be provided with a cover bolt.

2.9 Brass Fittings

2.9.1 All brass items shall be manufactured by Mueller Company, or A.Y. McDonald Mfg., Co.

2.10 Flexible Pipe Couplings

2.10.1 Flexible pipe couplings shall be manufactured by Dresser Industries Style No. 153 or Ford Style FC1 or Smith Blair Series 441 or Romac Style 501. Couplings shall be complete with middle ring, followers, gaskets, bolts and nuts.

2.11 Tapping Sleeve and Valve

2.11.1 The tapping sleeve shall be of same size as existing water main and shall be the type recommended by the manufacturer for the specific pipe to be tapped.

2.11.2 All tapping valves shall conform in all respects to the AWWA Specification C500 latest edition. The tapping valve shall be non-rising stem, double disc, iron body, bronze-mounted type, with O-ring stem seals and shall be counterclockwise opening.

2.11.3 Tapping sleeves and valves shall be designed to withstand a normal non-shock operating pressure of 150 psi.

2.11.4 Tapping valves shall be flanged joint at one end to meet with the flanged joint of the tapping sleeve, and mechanical joint at the other end. Gate valve shall be equipped for burial service with a 2-inch square-operating nut and conform to AWWA C-500 latest edition.

2.11.5 Tapping valves 14 inches and larger shall be equipped with bypass valve.

2.12 Restraining Rods and Clamps

2.12.1 Tie rods and nuts shall have minimum yield strength of 70,000 psi.

2.12.2 Clamps shall be fabricated of not less than ½" x 2" barstock. Rods and bolts shall have a minimum diameter of ¾". Cor-Ten bolts shall be used on all buried mechanical joints.

2.13 Hydrants

2.13.1 Hydrants shall be Clow Eddy and shall conform in all respects to AWWA Specification C502 latest edition.

2.13.2 The hydrant main valve shall have a minimum size of 5 inches and shall open counterclockwise. Each hydrant shall be equipped with two 2-1/2-inch hose nozzles and one (1) 4-1/2-inch pumper nozzle. The one (1) 4-1/2-inch hose nozzle shall have threads in conformance with National Standard as found in APPA No. 194. The two (2) 2-1/2 inch hose nozzles shall be National Standard Thread. The inlet shall be 6-inch mechanical joint type with accessories. Nozzle caps, gaskets, and chains shall be provided. These requirements shall be verified by the local fire department and any other water superintendent if any Intercommunity Agreement exists as per stated in the Local Law for Town of Ulysses Public Water.

2.13.3 All hydrants shall be painted red to match existing Town hydrants.

2.13.4 Hydrant markers shall be installed on each hydrant. Hydrant markers shall consist of a minimum 4-foot high pole with a flag on top.

The pole shall be made of galvanized steel, fiberglass, or carbon steel with a polyester finish for corrosion resistance. The pole shall be mounted by an integral ½” diameter loop for mounting behind the cap of a standard 2-1/2 inch NST barrel. The pole shall also have a heavy coil spring at base for flexibility. The flag shall be minimum 16 square inches and shall be faced with reflective tape.

2.14 Meters

2.14.1 Meters shall be Invensys-SR with a remote mounted readout or Neptune Model T-10 with remote touch pad reader. All meters shall be FM approved and should meet AWWA C700 standards.

2.15 Tile Set Meter Box

2.15.1 All tile set meter boxes shall be Mueller/McCullough Therma-Coil Meter Box as manufactured Mueller Co., Ford meter boxes or other such similar boxes for cold climates as approved by the water superintendent and consulting engineers.

2.15.2 All tile set meter boxes shall include a round locking cast iron lid for use in cold climates and contain a precast hole for a remote touch pad reader. The manufacturer of the meter box shall manufacture the lid and a closed cell-insulating pad shall also be provided.

2.16 Backflow Prevention Valve

2.16.1 All backflow prevention valves shall be reduced pressure zone type and rated for a maximum operating pressure of 150 psi. The backflow prevention valve shall meet or exceed all requirements of

AWWA Standard C506, as most recently revised. The backflow prevention valve shall also comply with all requirements of Technical Reference Item No. PWS-14 by the NYSDOH Office of Public Health.

2.16.2 The backflow prevention valve shall be of a make and model listed in Technical Reference Item No. PWS-14 by the NYSDOH Office of Public Health, such as Watts Regulator Series 909 or Conbraco Series 40-200, and subject to approval by the Superintendent.

2.16.3 Backflow preventers shall be installed when required by State or Local Code and when requested by the Superintendent.

2.17 Pressure Reducing Valve

2.17.1 All pressure reducing valves shall be designed for residential, commercial and industrial applications and a maximum operating pressure of 150 psi. All pressure reducing valves shall be Watts Regulator Series U5, or equal and subject to approval by the Superintendent. Pressure reducing valves shall be installed on all services. Pressure reducing valves shall be installed on the supply side of the meter except for tile set meters. Pressure reducing valves for the tile set meters shall be installed inside the building being served with water.

2.18 Thrust Blocks

2.18.1 Thrust blocks shall be constructed of concrete having 3,000-psi compressive strength at 28 days. In general, thrust blocks in combination with restrained joints shall be used to restrain thrust.

2.19 Lining, Special Backfill and Special Backfill Mix

2.19.1 All granular materials shall be free from any organic or other deleterious materials.

2.19.2 The quality of the gravel or stone particles shall be determined by the Magnesium Sulphate Soundness Test. The maximum percent loss at four (4) cycles, by weight, shall be twenty (20).

2.19.3 Lining shall consist of clean, sound, crushed stone and shall be free from coatings. Lining shall have the following ASTM No. 67 gradation by weight:

<u>% Passing</u>	<u>Sieve</u>
100	1"
90 - 100	3/4"
20 - 55	3/8"
0 - 10	No. 4
0 - 5	No. 8

2.19.4 Special Lining shall consist of a specially-blended mixture of not more than two approved local washed sands and one approved local screened gravel, mixed in the field as directed by the Superintendent. Special Lining shall have the following gradation by weight:

<u>% Passing</u>	<u>Sieve</u>
100	2"
20 - 70	No. 40
2 - 10	No. 200

2.19.5 Special Backfill shall consist of washed coarse sand, gravel or broken stone. The gravel or broken stone shall be well graded from fine to coarse. Special Backfill shall have the following gradation by weight:

<u>% Passing</u>	<u>Sieve</u>
100	2"
30 - 65	1/4"

0 - 10

No. 200

For Special Backfill, the result of multiplying the percentage passing the No. 200 sieve by the Plasticity Index of the particles passing the No. 40 sieve shall not exceed thirty (30.0). In no case shall the Plasticity Index exceed five (5.0), or the percentage passing the No. 200 mesh sieve exceed ten percent (10%). Of the particles retained on the one-half inch (½") square sieve, not more than thirty percent (30%) by weight shall consist of flat or elongated pieces. A flat or elongated piece is defined herein as one, the greatest dimension of which is more than three (3) times the least dimension.

2.19.6 Special Backfill Mix shall consist of dry cement with gravel, meeting the Specifications for Special Backfill, mixed in the proportion of one to fifteen (1:15) by volume.

2.19.7 The Customer shall employ an approved commercial testing laboratory at his own expense to conduct sieve analysis, plasticity index and soundness tests prior to delivery of any of the materials to the site of the project. The Superintendent may, at the Customer's expense, require additional tests if, in his opinion, the quality of the materials has changed.

3.0 INSTALLATION

3.1 General

3.1.1 The following details are to be referenced for installation of items specified in this Section:

- a. Figure 1 - "Pipe Laying Detail"
- b. Figure 2 - "Typical Crossing - Culvert, Sanitary Sewer or Drainage"

Course”

- c. Figure 3 - “Valve Box for 12-Inch Valves and Smaller”
- d. Figure 4- “Hydrant Assembly”
- e. Figure 5 - “3/4" or 1" Service Connection”
- f. Figure 6 - “Water Meter Installation”
- g. Figure 7 - “Tile Set Meter Detail for Buildings with Greater Than 150-Foot Setback”

3.1.2 Local utilities shall be contacted to verify construction plans and to make arrangements to disconnect all utility services, where required to undertake the construction work. The utility services shall later be reconnected. The work shall be scheduled so that there is minimum inconvenience to local residents. Residents shall be provided proper and timely notice regarding disconnection of utilities.

3.1.3 The construction right-of-way shall be cleared only to the extent needed for construction. Clearing consists of removal of trees which interfere with construction, removal of underbrush, logs, and stumps, and other organic matter, removal of refuse, garbage, and trash, removal of ice and snow, and removal of telephone and power poles, and posts. Any tree, which will not hinder construction, shall not be removed, and shall be protected from damage by any construction equipment. Debris shall not be burned, but hauled for disposal in an approved manner.

3.1.4 The public shall be protected from personal and property damage as a result of the construction work.

3.1.5 Traffic shall be maintained at all times in accordance with applicable highway permits.

3.1.6 Erosion control shall be performed throughout the project to minimize the erosion of soils onto lands or into waters adjacent to or affected by the work. Erosion control can be affected by limiting the amount of clearing and grubbing prior to trenching, proper scheduling of the pipe installation work, minimizing time of open trench, prompt grading and seeding, and filtration of drainage.

3.1.7 The trench shall be excavated only wide enough for proper installation of the water main and appurtenances. Allowances may be made for sheeting, de-watering, and other similar actions to complete the work. Roads, sidewalks, and curbs shall be cut, by sawing or by other methods as approved by the agency of jurisdiction, before trench excavation is initiated.

3.1.8 Under ordinary conditions, excavation shall be by open cut from the ground surface. However, tunneling or boring under structures other than buildings may be permitted. Such structures include crosswalks, curbs, gutters, pavements, trees, driveways, and railroad tracks.

3.1.9 Open trenches shall be protected at all hours of the day with barricades, as required.

3.1.10 Trenches shall not be open for more than 30 feet in advance of pipe installation nor left unfilled for more than 30 feet in the rear of the installed pipe, when the work is in progress, without permission of the Superintendent. When work is not in progress, including overnight, weekends, and holidays, the trench shall be backfilled to ground surface.

3.1.11 Maintenance of grade, elevation, and alignment shall be done by some suitable method or combination of methods.

3.1.12 No structure shall be undercut unless specifically approved by the Superintendent.

3.1.13 Proper devices shall be provided, and maintained operational at all times, to remove all water from the trench as it enters.

3.1.14 Sheeting, bracing and shoring shall be furnished, placed and maintained as may be required to support the sides and ends of excavations in such manner as to prevent any movement which could, in any way, injure the pipe, valve, hydrant, or other work; diminish the width necessary; otherwise damage or delay the work; or endanger existing structures, pipes or pavements; cause the excavation limits to exceed the right-of-way limits; or to occasion a hazard to persons engaged on the project or to the general public.

In no case will bracing be permitted against pipes or structures in trenches or other excavations.

The Town of Ulysses, the Superintendent, and the Town Engineer shall not be responsible for the safety and adequacy of sheeting, bracing and/or shoring. In general, all sheeting, bracing and shoring shall be withdrawn by a method that will prevent settlement. If it is necessary that sheeting be left in place, it shall be cut off or driven down so that no portion of the same shall remain within twelve (12) inches of the finished street or ground surface.

3.1.15 Lining shall be used for backfilling below subgrade in trenches for pipelines or excavations for structures, provided the sides and bottom of the excavations will remain stable when wet. Special Lining shall be used for backfilling below subgrade in trenches and excavations where the sides and bottom of the excavation will not, in the opinion of the Superintendent, remain stable when wet.

3.1.16 Lining shall be placed over the laid pipe to a depth of at least twelve (12) inches. Care shall be exercised so that stone is packed under the pipe haunches. Care shall be exercised so that the pipe is not moved during placement of the lining.

3.1.17 Where directed by the Superintendent or required by the agency of jurisdiction, Special Backfill shall be used for backfilling excavations in streets, roads, or drives, and in areas upon which structures are to be built or where the excavated material is, in the opinion of the Superintendent, unsuitable for backfilling.

3.1.18 Special Backfill Mix shall be used under paved highways and shoulders and for other backfilling operations as directed by the Superintendent.

3.1.19 Lining, Special Lining, Special Backfill and Special Backfill Mix shall be placed in horizontal layers not more than eight (8) inches in thickness and shall be so thoroughly and uniformly compacted as to prevent after-settlement. Compaction shall be by traveling vibrators or other approved method and shall be to 95% of the maximum dry weight density in pounds per cubic foot as determined by the Modified Proctor Compaction Test (ASTM Specification D1557).

3.1.20 All Lining, Special Lining and Special Backfill shall be inspected and approved by the Superintendent before any pipelines are laid or any forms for structures are placed.

3.1.21 Any settlement in the finished work due to settlement of the compacted Lining, Special Lining, or Special Backfill shall be made good by the Customer at his own cost and expense.

3.1.22 The Customer shall employ an approved commercial testing laboratory at his own expense to conduct the compaction tests.

Each layer shall be tested and approved by the Superintendent before succeeding layers are placed. A minimum of one field density test shall be made each day and/or for each fifty (50) cubic yards of material placed and/or as shown or specified in the Drawings.

The following reports in quadruplicate shall be submitted directly to the Superintendent:

- a. Report and Certification of Gradation.
- b. Field Density Reports.
- c. One optimum moisture-maximum density curve for each type of fill.

Based on the reports of the testing laboratory and inspection, if the subgrade or fills which have been placed and compacted are below the specified density, the Superintendent will ask for additional compaction and testing at the expense of the Customer.

3.1.23 Bell holes shall be hand excavated, as appropriate.

3.1.24 The migration of fines from surrounding backfill or native soils shall be restricted by gradation of embedment materials or by use of suitable filter fabric.

3.1.25 The remaining portion of the trench above the pipe embedment shall be backfilled in one-foot lifts, which shall be firmly compacted. Compaction near/under roadways, driveways, sidewalks, and other structures shall be to 95% of the maximum dry weight density in pounds per cubic foot, as determined by the Modified Proctor Compaction Test (ASTM Specification D1557).

3.2 Installation of Ductile Iron Water Mains and Appurtenances

3.2.1 All ductile iron water mains and their appurtenances shall be installed in accordance with AWWA C600, latest edition.

3.2.2 Water mains shall be installed at a minimum depth of five (5) feet from the top of pipe to finished grade.

3.2.3 Pipe shall be laid on a prepared earth subgrade or lining as shown on Figure 1 - "Pipe Laying Detail", as directed by the Superintendent. Lining shall be placed in the trench and tamped uniformly along the full length of pipe. Blocking under the pipe shall not be used without specific approval of the Superintendent.

3.2.4 For water mains crossing sewers, a minimum vertical clearance of 18 inches between the outside of the water main and the outside of the sewer shall be provided as shown on Figure 2 - "Typical Crossing - Culvert, Sanitary Sewer or Drainage Course". This shall be the case

where the water main is either above or below the sewer. For water mains crossing drainage courses, a minimum vertical clearance of 18 inches between the lowest elevation of the drainage course and the top of the water main shall be maintained. At crossing, one full length of water pipe shall be located so both joints will be as far from the sewer or drainage course as possible. Provide special structural support for the water and sewer pipes as required.

3.2.5 Two brass wedges shall be inserted securely between bell and spigot ends of pipes, maintaining the full water tightness of the pipe.

3.2.6 All new mains, including stubs, shall be thoroughly flushed at a minimum velocity of 2.5 ft./sec. prior to pressure testing.

3.2.7 All new mains shall be hydrostatically tested in accordance with the procedures of AWWA C600. The pipe shall be tested for strength and tightness under a hydrostatic pressure of at least 1.25 times the maximum pressure at lowest point along the test section, or 150 psi, whichever is greater. This pressure shall be maintained for at least two hours with all valves and connections shut. The test pressure shall not vary by more than 5 psi for the duration of the test. Any exposed pipe, fittings and joints shall be examined carefully during the test. Any damaged or defective pipe, fittings, or joints that are discovered during or after the test shall be repaired or replaced. Pressure tests shall normally be made between gate valves.

3.2.8 All new water mains shall be disinfected in accordance with AWWA C651 using either a chlorine-gas water mixture or a 12% liquid sodium hypochlorite solution.

3.2.9 Water required for testing and flushing of new water mains may be obtained from the Town of Ulysses upon completion of new water main. The Customer shall pay the Town of Ulysses for water used for testing in accordance with the latest water rate schedule. Disposal of test water, and all costs associated with such, shall be the responsibility of the Customer.

3.3 Tapping Sleeve and Valve Installation

3.3.1 The existing pipe to be tapped shall be carefully exposed sufficient to install the tapping sleeve. Installation of the tapping sleeve shall be in accordance with the manufacturer's recommendations.

3.4 Valve Box Installation

3.3.1 Valve boxes shall be kept centered and plumb over the operating nut of the valve. All valve box covers shall be set approximately one inch below the ground surface, or as directed by the Superintendent, as shown on Figure 3 - "Valve Box for 12-Inch Valves and Smaller".

3.5 Curb Box Installation

3.5.1 Curb boxes shall be installed as shown on Figure 5 - "3/4" or 1" Service Connection", or as otherwise directed by the Superintendent.

3.6 Service Line Installation

Service lines shall be installed at a minimum two feet separation from other utility lines (electric, gas, telephone etc.) or as otherwise required by

the utility supplier. In addition, all service lines shall have a clearance of at least 18 inches between the outside of the service line and the outside of the septic (or sewer) or as otherwise required by the Tompkins County Health Department and other authorities having jurisdiction.

3.7 Flexible Coupling Installation

3.7.1 Flexible couplings shall be installed in accordance with manufacturer's instructions. All flexible couplings shall be provided with polyethylene encasement in accordance with AWWA C105.

3.7.2 Each coupling shall be tested for water tightness at 1.5 the maximum pressure of the completed pipeline. Testing shall be completed prior to field application of polyethylene encasement.

3.8 Hydrant Installation

3.8.1 All hydrants shall be installed as shown on Figure 4 - "Hydrant Assembly". The hydrant shall be harnessed to the main line using tie rods and lug fasteners.

3.8.2 Hydrants shall be installed plumb and with proper barrel length so as to locate the hose nozzles at least eighteen (18) inches, but not more than thirty (30) inches, above the level of the edge of the highway on which it fronts, unless otherwise directed. Hydrant shall be furnished with frangible break flange and break coupling at the ground line.

3.8.3 Hydrant shall be equipped with an automatic drain, independent of main valve, to provide removal or adjustment without shutting off water, and can be cleaned without digging.

3.8.4 Where the hydrant is to be located between a drainage swale and right-of-way boundary, a 20-foot section of at least 12-inch diameter corrugated metal pipe with end sections shall be installed in the existing swale and backfilled. Larger culverts shall be provided at the discretion of the authority having jurisdiction. Where a downstream or upstream culvert exists which is larger than 12 inches in diameter, a culvert with diameter equal to that of the larger culvert shall be installed.

3.9 Meter Installation

3.9.1 Meters shall be installed in accordance with Figure 6 - "Water Meter Installation, or Figure 7 - "Tile Set Meter Detail for Buildings With Greater Than 150-Foot Setback", if building setback from water main exceeds 150 feet, specifications and manufacturer's instructions. Meters and remote touch pad reader shall be installed in an accessible location acceptable to the Superintendent.

3.9.2 Pipes shall be thoroughly flushed prior to installation of water meters. After installation, meters shall be visually inspected to insure proper operation.

3.9.3 All tile set meters shall be installed in accordance with Figure 7 - "Tile Set Meter Detail for Buildings with Greater Than 150-Foot Setback", specifications, and manufacturer's instructions.

3.10 Backflow Prevention Valve Installation

3.10.1 Backflow prevention valves shall be installed in accordance with plans, specifications, manufacturer's instructions, and guidelines as

specified by the NYSDOH as contained in “Guidelines For Designing Backflow Prevention Assembly Installations - Supplement to the 1981 Cross Connection Control Manual (January 1992).

3.10.2 The backflow prevention valve shall be tested by a certified tester at the time of installation to ensure that the valve is operating properly.

3.11 Pressure Reducing Valve Installation

3.11.1 Pressure reducing valves shall be installed in accordance with plans, specifications, and manufacturer’s instructions.

STANDARD DETAILS

FIGURE 1

PIPE LAYING DETAIL

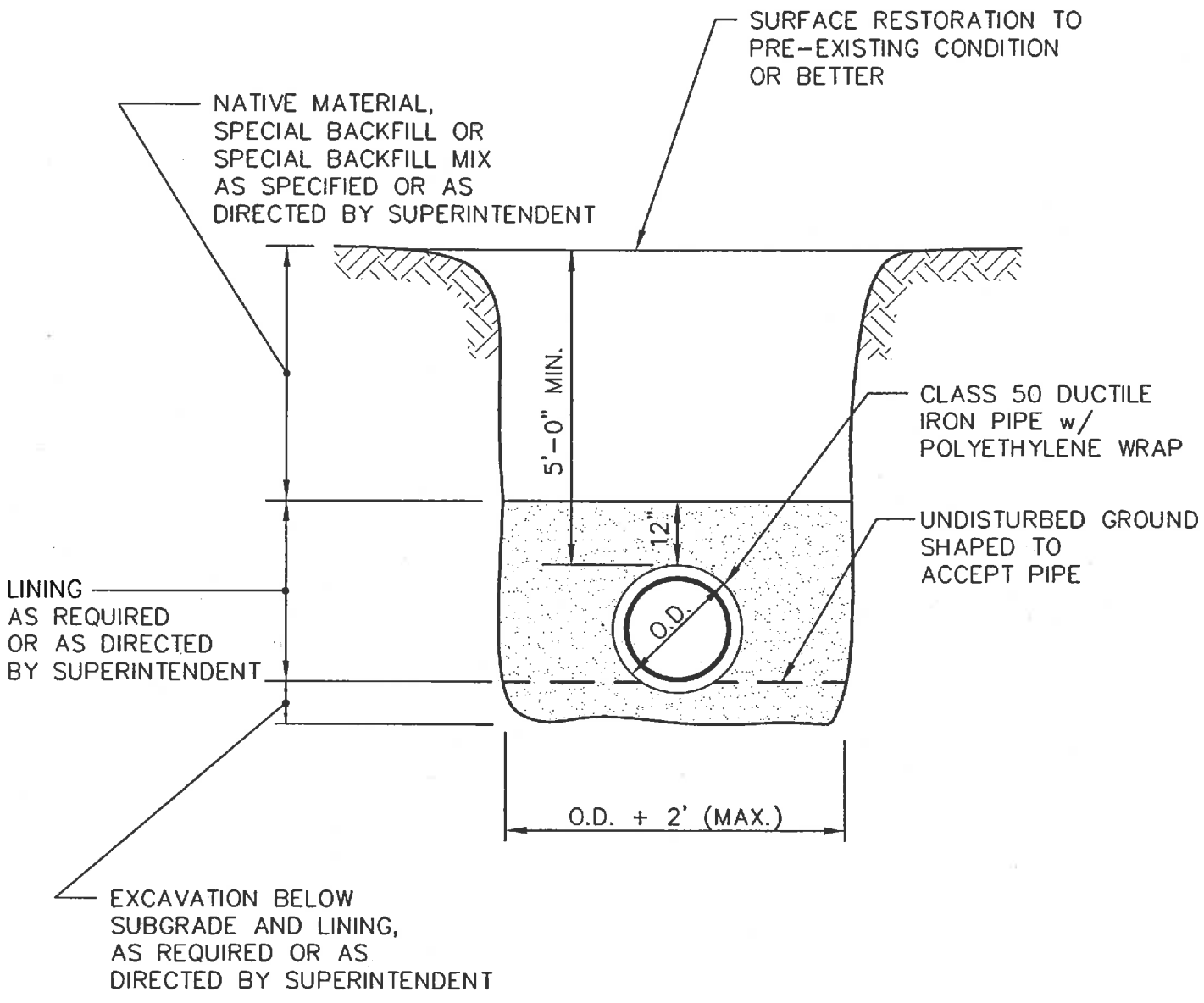

Barton
Loguidice, P.C.
 Consulting Engineers

290 Elwood Davis Road / Box 3107, Syracuse, New York 13220

TOWN OF ULYSSES
 WATER DEPARTMENT
 STANDARD DETAILS
PIPE LAYING DETAIL

TOMPKINS COUNTY

NEW YORK

Figure

1

Project No.

586.010

FIGURE 2

**TYPICAL CROSS
(CULVERT, SANITARY SEWER OR DRAINAGE COURSE)**

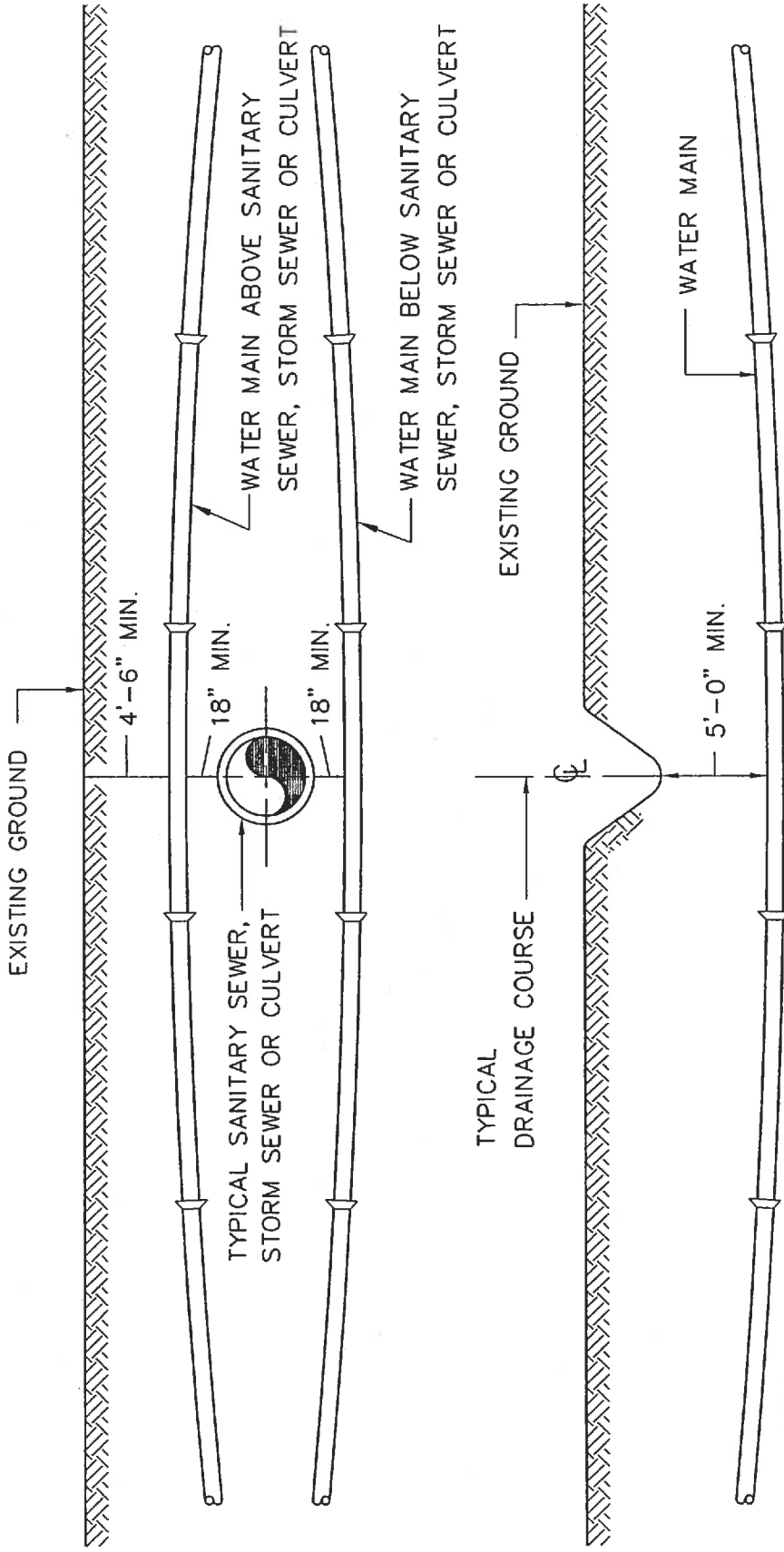

NOTES:

- 1) CROSSING SHALL BE ACCOMPLISHED BY PIPE DEFLECTION, WITH NO RELATIVE PIPE DEFLECTION TO EXCEED 9.5" PER 18' LENGTH OF PIPE, UNLESS OTHERWISE DIRECTED BY THE SUPERINTENDENT.
- 2) A FULL LENGTH OF PIPE SHALL BE CENTERED ON THE CULVERT, SEWER OR DRAINAGE COURSE CENTERLINE.

Figure
2
 Project No.
 586.010

TOWN OF ULYSSES
 WATER DEPARTMENT
 STANDARD DETAILS
TYPICAL CROSSING
 CULVERT, SANITARY SEWER
 OR DRAINAGE COURSE
 TOMPKINS COUNTY NEW YORK

Barton
Blodigudice, P.C.
 Consulting Engineers
 290 Elwood Davis Road / Box 3107, Syracuse, New York 13220

FIGURE 3

VALVE BOX FOR 12-INCH VALVES AND SMALLER

COVER TO HAVE "WATER"
CAST IN TOP WITH ARROW
POINTING IN COUNTERCLOCKWISE
DIRECTION WITH THE WORD "OPEN"

SET ONE INCH BELOW
GRADE OR AS DIRECTED
BY THE SUPERINTENDENT

NRS RESILIENT SEATED
MJ GATE VALVE MEETING
AWWA C509
OPEN LEFT

VALVE BOX
5 1/4" SHAFT
3 PIECE SCREW TYPE
INSTALLED PLUMB

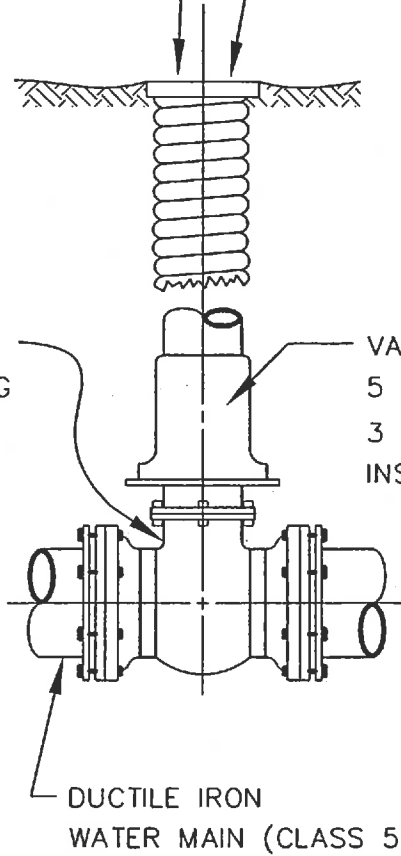

DUCTILE IRON
WATER MAIN (CLASS 50)

Barton
& Loguidice, P.C.
Consulting Engineers

290 Elwood Davis Road / Box 3107, Syracuse, New York 13220

TOWN OF ULYSSES
WATER DEPARTMENT
STANDARD DETAILS

VALVE BOX FOR
12" VALVES AND SMALLER

TOMPKINS COUNTY

NEW YORK

Figure

3

Project No.

586.010

FIGURE 4

HYDRANT ASSEMBLY

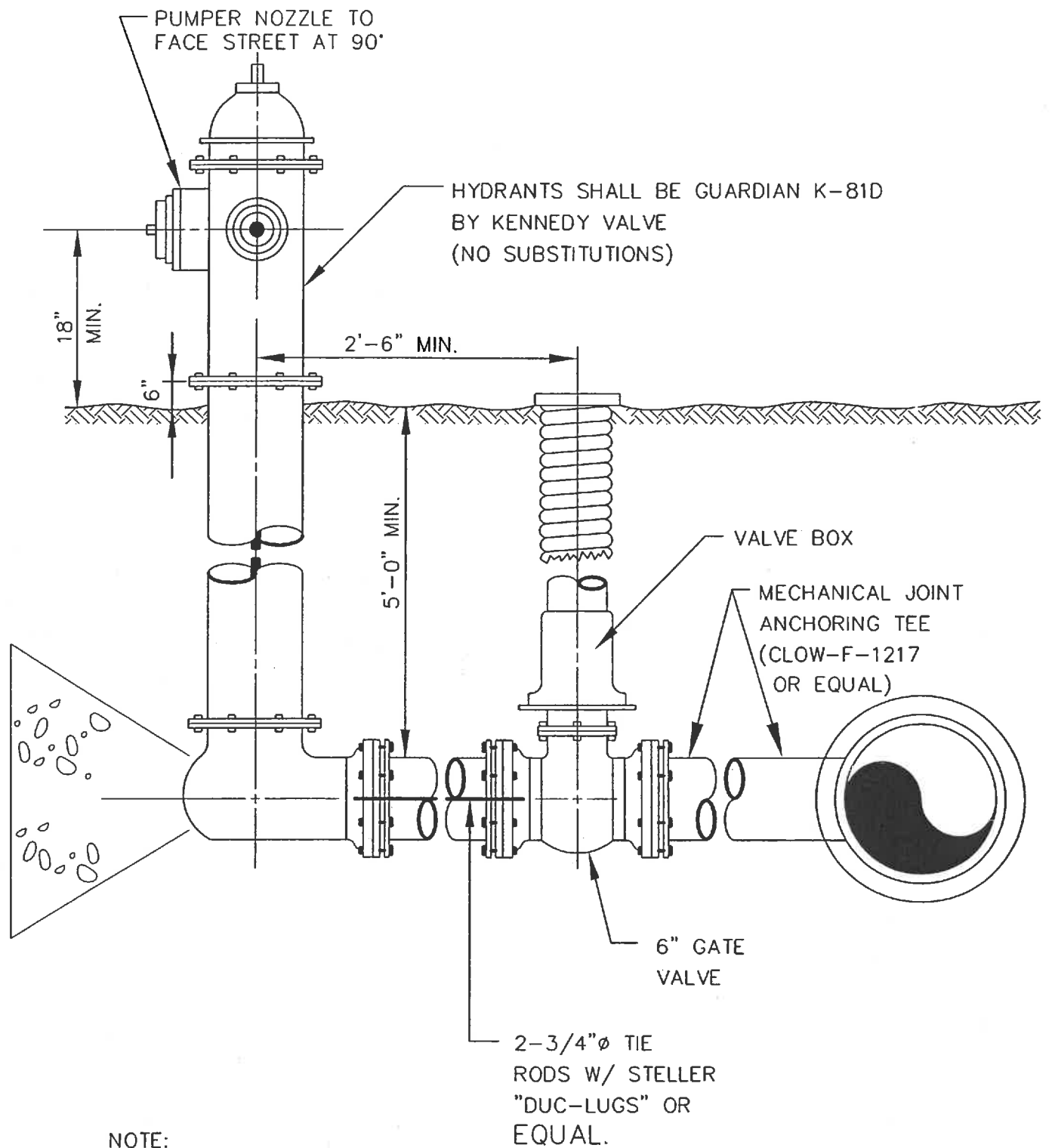

NOTE:

- 1) TWO FORMS OF RESTRAINTS SHALL BE REQUIRED

Barton
& Loguidice, P.C.
 Consulting Engineers

290 Elwood Davis Road / Box 3107, Syracuse, New York 13220

TOWN OF ULYSSES
 WATER DEPARTMENT
 STANDARD DETAILS
HYDRANT ASSEMBLY

TOMPKINS COUNTY

NEW YORK

Figure

4

Project No.

586.010

FIGURE 5

3/4" OR 1" SERVICE CONNECTION

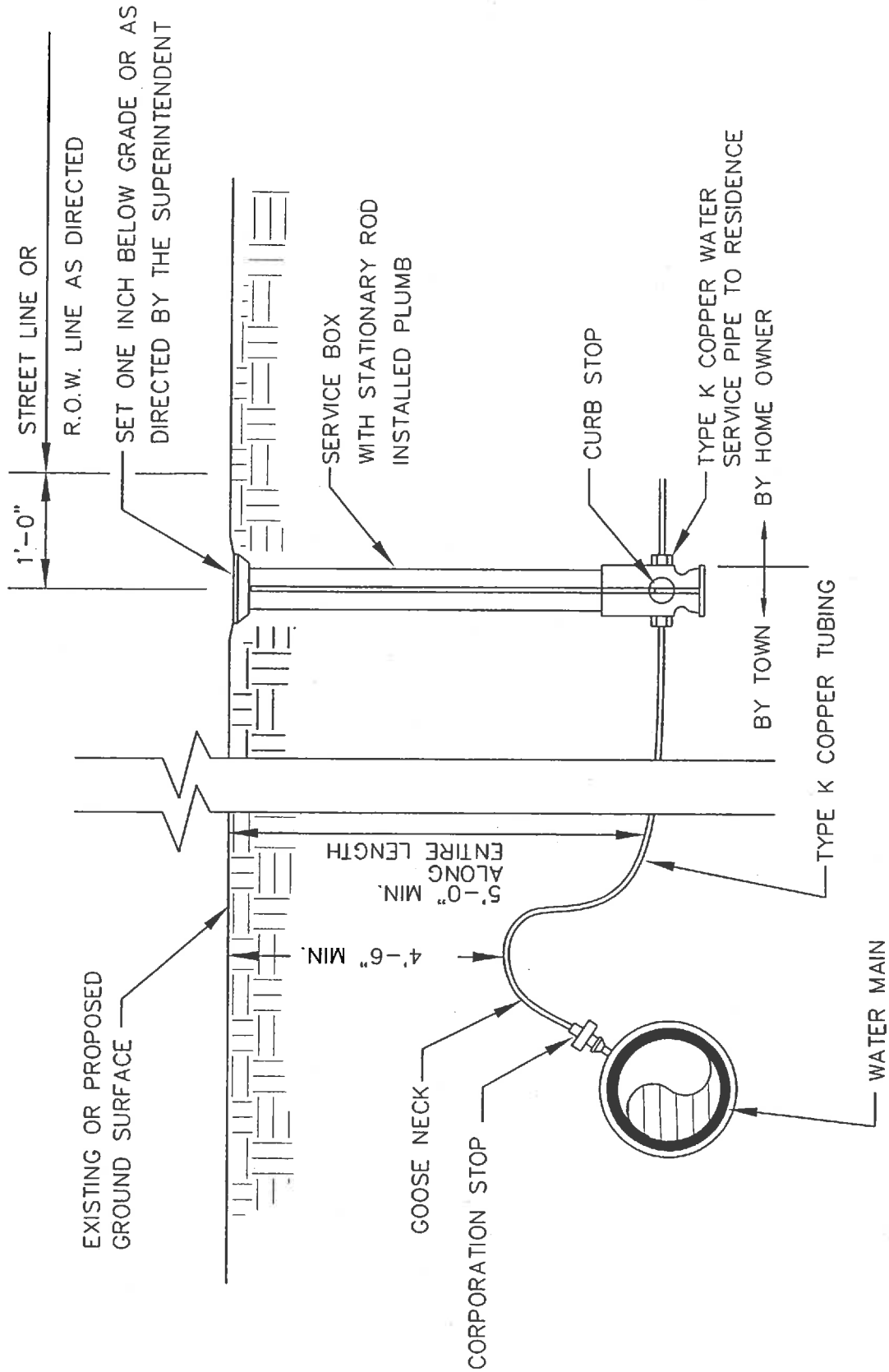

Figure
5
 Project No.
 586.010

TOWN OF ULYSSES
 WATER DEPARTMENT
 STANDARD DETAILS
3/4" OR 1" SERVICE CONNECTION
 TOMPKINS COUNTY NEW YORK

Barton
oguidice, P.C.
 Consulting Engineers
 290 Elwood Davis Road / Box 3107, Syracuse, New York 13220

FIGURE 6

WATER METER INSTALLATION

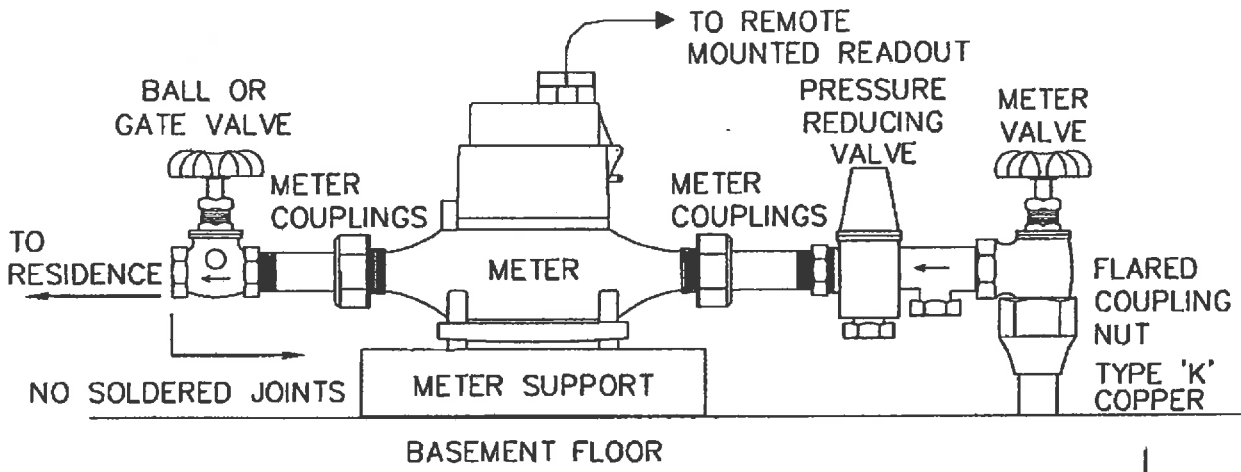

BASEMENT FLOOR

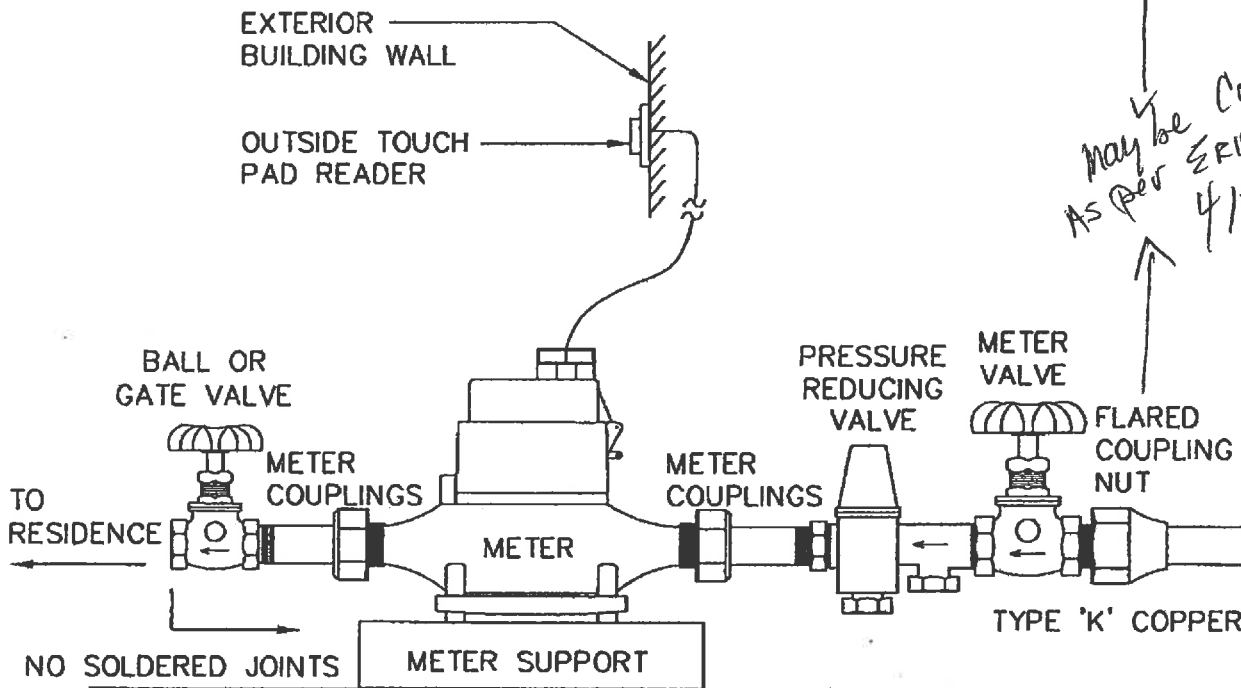

BASEMENT FLOOR

*May be compressed
AS per ERIC
4/23/04*

NOTES:

- 1) NO SOLDERED JOINTS BEFORE METER
- 2) ONLY BRASS OR COPPER BEFORE METER
- 3) METER SHALL BE INSTALLED AS CLOSE AS REASONABLY POSSIBLE TO "POINT OF ENTRY" OF WATER SERVICE TO BUILDING, AND ALL PIPING BEFORE METERS SHALL REMAIN EXPOSED.
- 4) METER SHALL BE INSTALLED LEVEL.
- 5) METERS LARGER THAN 1" CONSIDERED ON AN INDIVIDUAL BASIS.
- 6) METER TO BE PROVIDED BY TOWN OF ULYSSES.



280 Elwood Davis Road / Box 3107, Syracuse, New York 13220

TOWN OF ULYSSES
WATER DEPARTMENT
STANDARD DETAILS
WATER METER
INSTALLATION

TOMPKINS COUNTY

NEW YORK

Figure

6

Project No.

586.010

FIGURE 7

**TILE SET METER DETAIL FOR BUILDINGS GREATER THAN
150-FOOT SETBACK**

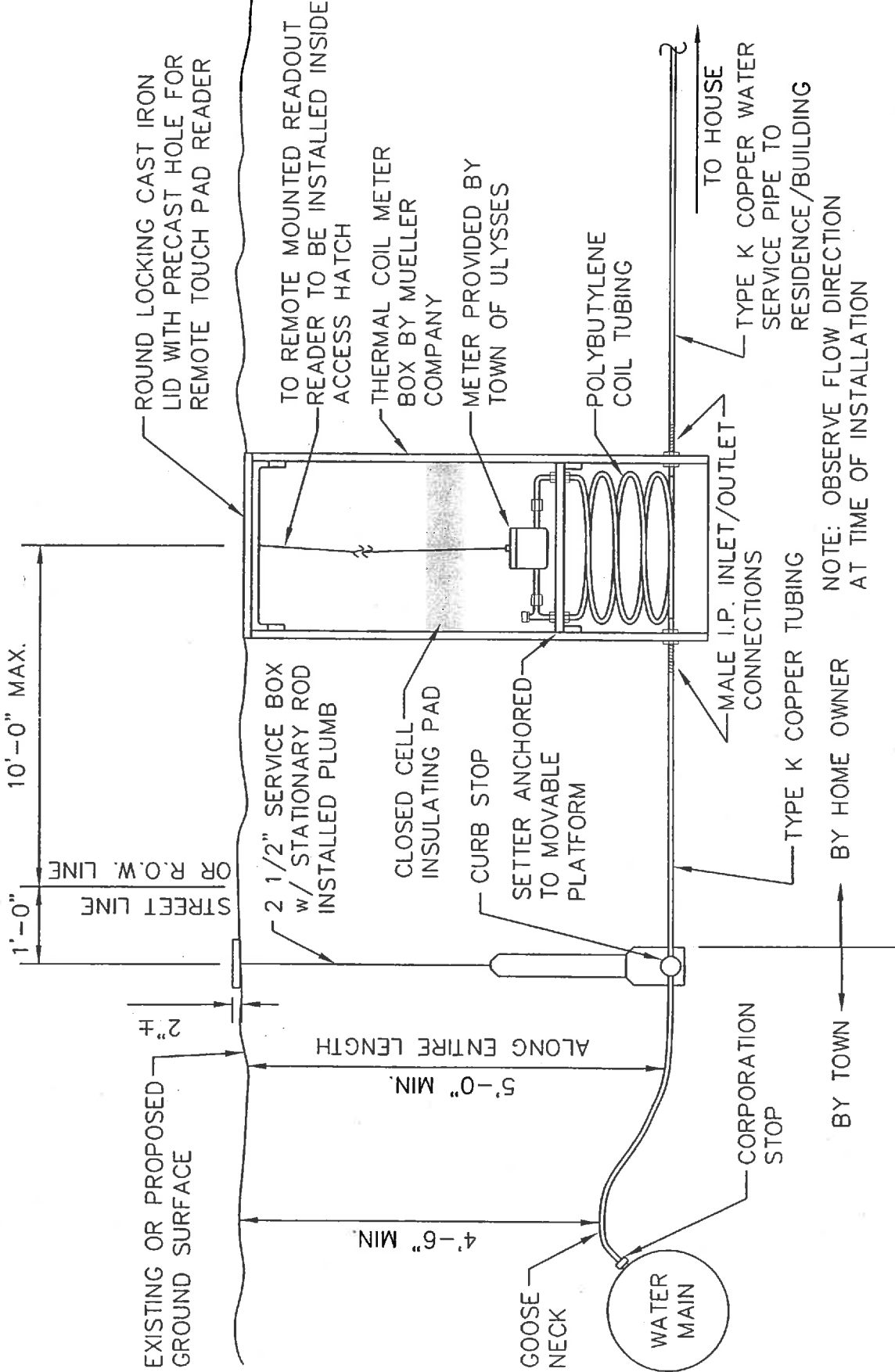

10'-0" MAX.

1'-0"

STREET LINE
OR R.O.W. LINE

EXISTING OR PROPOSED
GROUND SURFACE

2" ±

2 1/2" SERVICE BOX
w/ STATIONARY ROD
INSTALLED PLUMB

CLOSED CELL
INSULATING PAD

CURB STOP

SETTER ANCHORED
TO MOVABLE
PLATFORM

ALONG ENTIRE LENGTH

4'-6" MIN.

5'-0" MIN.

WATER
MAIN

CORPORATION
STOP

BY TOWN

BY HOME OWNER

MALE I.P. INLET/OUTLET
CONNECTIONS

TYPE K COPPER TUBING

TO HOUSE

TYPE K COPPER WATER
SERVICE PIPE TO
RESIDENCE/BUILDING

NOTE: OBSERVE FLOW DIRECTION
AT TIME OF INSTALLATION

ROUND LOCKING CAST IRON
LID WITH PRECAST HOLE FOR
REMOTE TOUCH PAD READER

TO REMOTE MOUNTED READOUT
READER TO BE INSTALLED INSIDE
ACCESS HATCH

THERMAL COIL METER
BOX BY MUELLER
COMPANY

METER PROVIDED BY
TOWN OF ULYSSES

POLYBUTYLENE
COIL TUBING

Figure
7
Project No.
586.010

TOWN OF ULYSSES
WATER DEPARTMENT
STANDARD DETAILS
TILE SET METER DETAIL
FOR BUILDINGS WITH GREATER
THAN 150 FT. SETBACK
TOMPKINS COUNTY NEW YORK

Barton
Boquice, P.C.
Consulting Engineers
280 Elwood Davis Road / Box 3107, Syracuse, New York 13220